

Fabricate a high-resolution sensor-to-USB interface

Zoltan Gingl, University of Szeged, Szeged, Hungary

The circuit in this Design Idea combines a mixed-signal microcontroller, a USB UART (universal asynchronous receiver/transmitter), and a novel adaptable analog sensor-input circuit. It allows you to connect many types of sensors to the design's two analog-input channels, control the device, and read measurement data on a USB host. The USB connection powers the circuit. You can control the device from your computer with simple commands; even terminal software can make the measurements. The 8051 core allows for easy programming with freely available tools, such as IDEs (integrated development environments), debuggers, and C compilers.

The design is based on a \$8 microcontroller that features an 8051 architecture, as well as a PGA (programmable-gain amplifier) and a 24-bit sigma-delta ADC (figures 1, 2, and 3). Microcontroller IC₁ has an input multiplexer allowing differential or single-ended mode and two DAC outputs, and it can provide five unassigned digital-I/O pins (Figure 1). One output pin drives D₁ under program control. The remaining digital pins are used to configure the two analog-input ports. You also send the microcontroller's reference output to one of the analog-input ports. Two configurable analog ports allow you to connect many sensor types using two three-input connectors, each of which has a ground pin (Figure 4). One ground pin provides 3.3V power, and the other outputs the buffered reference voltage—nominally, 2.5V. Wire

A 3.3V linear regulator, IC₂, powers the microcontroller (Figure 2). You power USB chip IC₁ directly from the USB port through a ferrite bead and a filter network. This popular and reliable USB UART chip lets you communicate with a computer using any operating system. Op amp IC₄ buffers the microcontroller's reference output (Figure 3).

Two configurable analog ports allow you to connect many sensor types using two three-input connectors, each of which has a ground pin (Figure 4). One ground pin provides 3.3V power, and the other outputs the buffered reference voltage—nominally, 2.5V. Wire

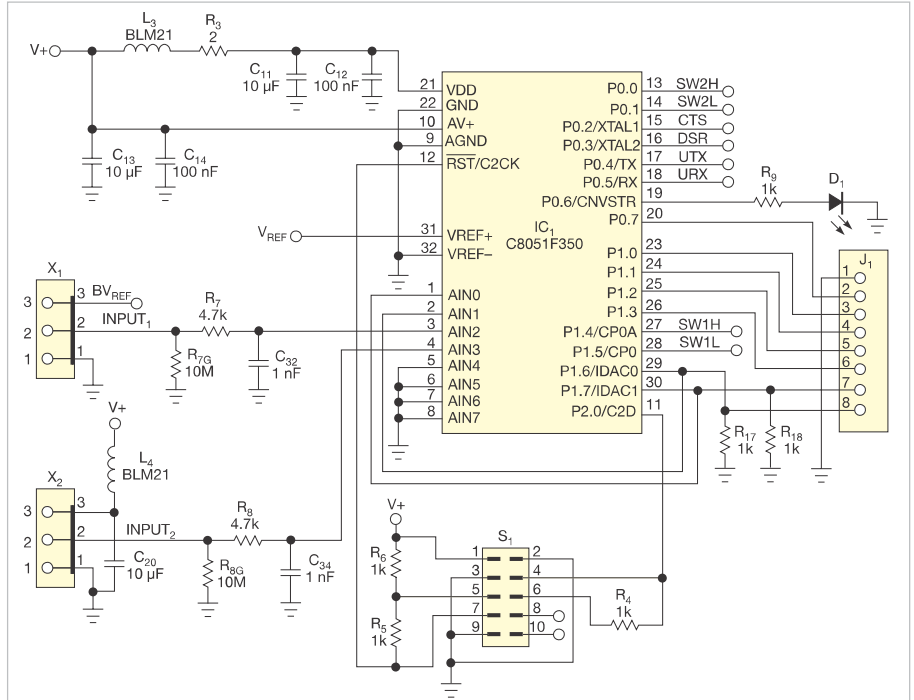

Figure 1 Microcontroller IC₁ has an input multiplexer allowing differential or single-ended mode and two DAC outputs, and it can provide five unassigned digital-I/O pins.

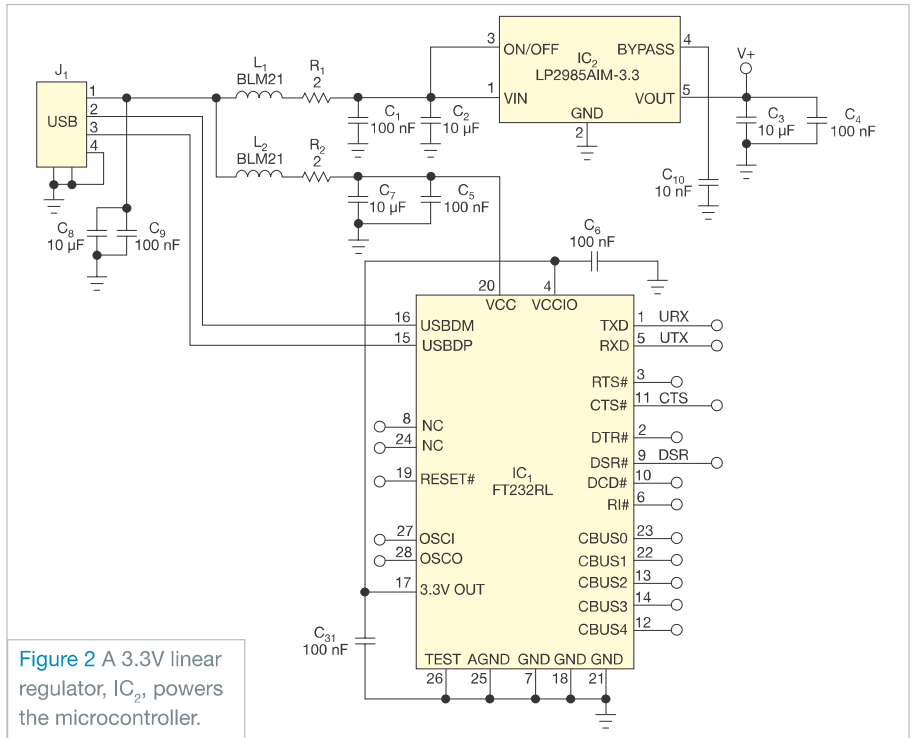

Figure 2 A 3.3V linear regulator, IC₂, powers the microcontroller.

designideas

the central pins of the two connectors to the microcontroller's analog-input multiplexer. In this way, you can either measure two single-ended voltages or use these two connectors as differential inputs. Both inputs have individually switched pullup and pulldown resistors, R_{10} , R_{11} , R_{14} , and R_{15} .

CURRENT-OUTPUT SENSORS CAN BE CONNECTED AS YOU WOULD CONNECT PHOTODIODES— BETWEEN THE GROUND AND THE INPUT PINS.

The analog-input architecture allows you to directly connect many kinds of sensors. For example, you can connect a thermistor or a photoresistor between the ground and the input pins and switch on the pullup resistor to form a voltage divider; the on-chip ADC can directly digitize this voltage divider's output (Figure 5). This approach also features ratiometric operation, meaning that the ADC uses the same reference as the driving voltage of the voltage divider. Current-output sensors can also be connected as you would connect photodiodes—directly between the ground and the input pins. Switch the pulldown resistor so that the photocurrent develops a voltage.

The high-resolution ADC and PGA allow direct connection of thermocouples (Figure 6). You achieve the required bias point by switching on both the pullup and the pulldown resistors on one channel. You can use directly connected bridge-type sensors, such as load cells and pressure sensors, by switching off all of the internal resistors. In these cases, you should operate the ADC in differential mode. Leaving all of the switches open also suits use in potentiometer inputs or IC sensors, such as the SS49E Hall-effect magnetic-field sensor.

When using directly connected sensors, you should consider source impedance, signal range, filtering, and noise

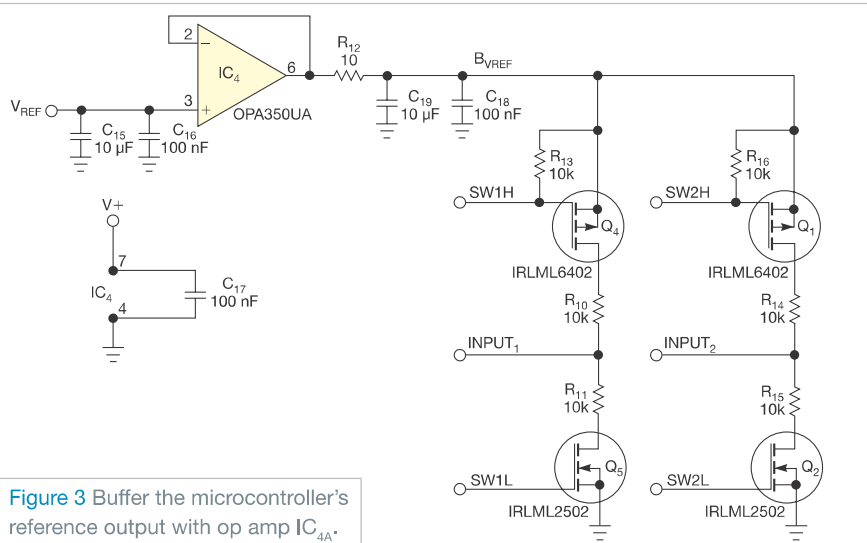

Figure 3 Buffer the microcontroller's reference output with op amp IC_{4A}.

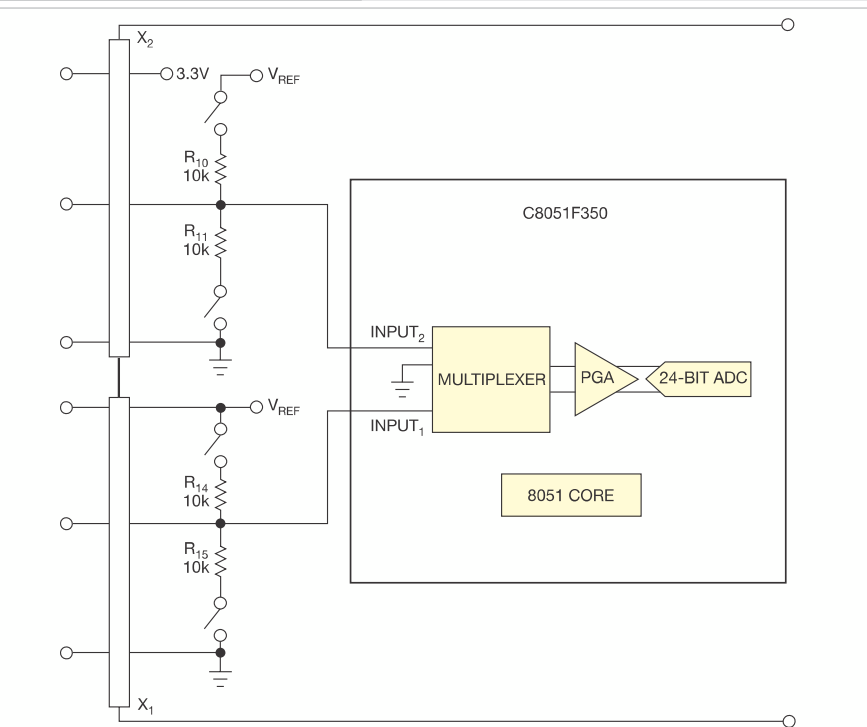

Figure 4 You create two configurable analog ports that allow you to connect many sensor types using two three-input connectors, each of which has a ground pin.

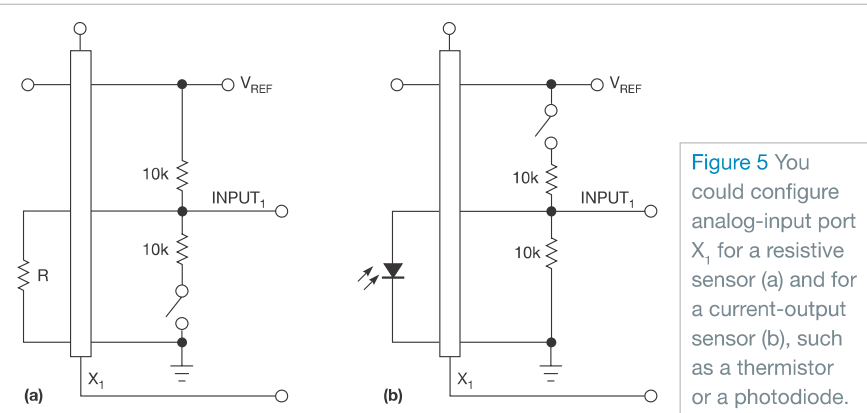

Figure 5 You could configure analog-input port X₁ for a resistive sensor (a) and for a current-output sensor (b), such as a thermistor or a photodiode.

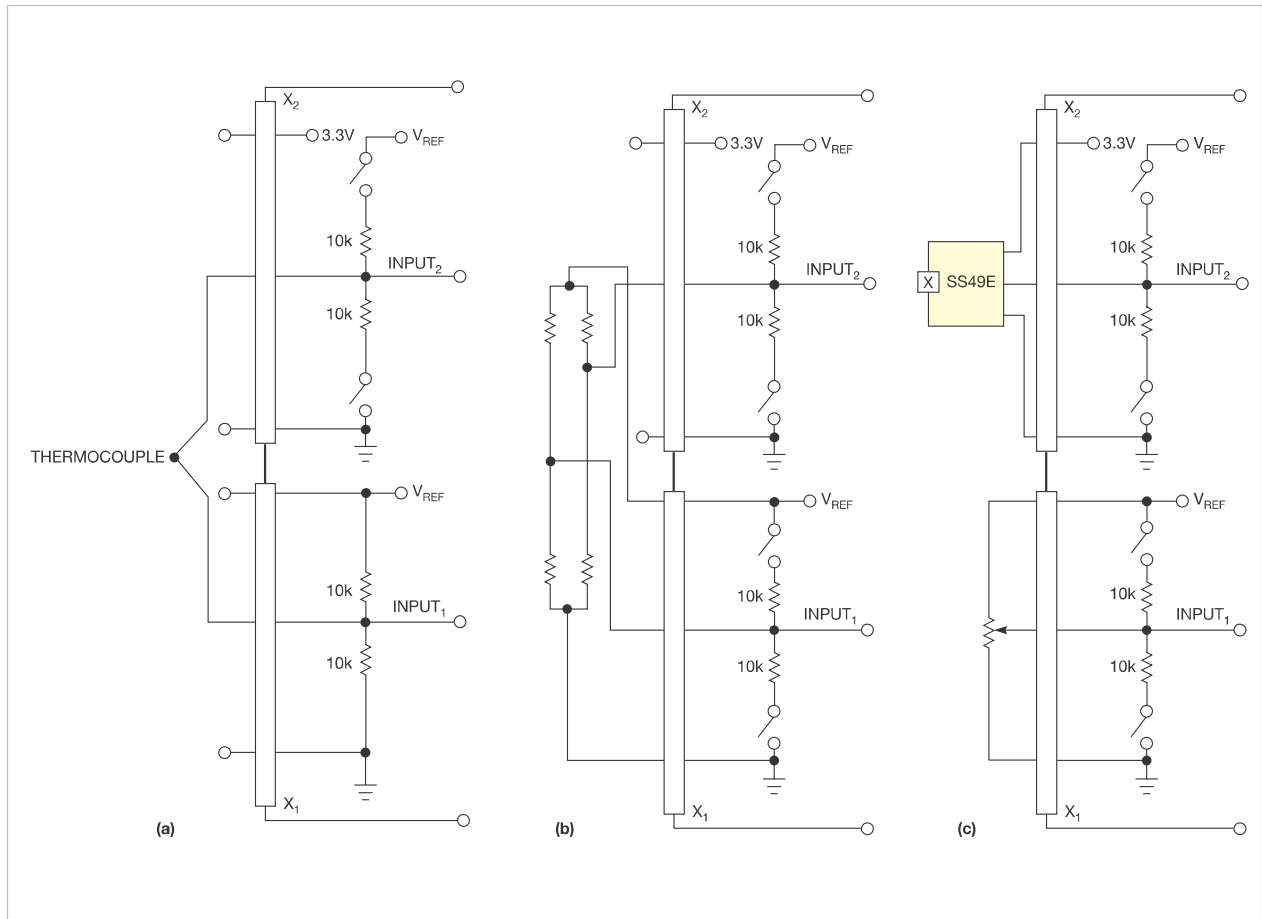

Figure 6 You can directly connect small-output voltage sensors (a), resistor bridges (b), or IC sensors and potentiometric sensors (c).

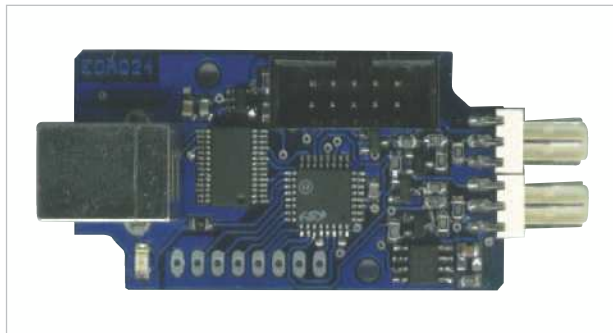

Figure 7 The design fits into a 2.36x1.38-in. enclosure.

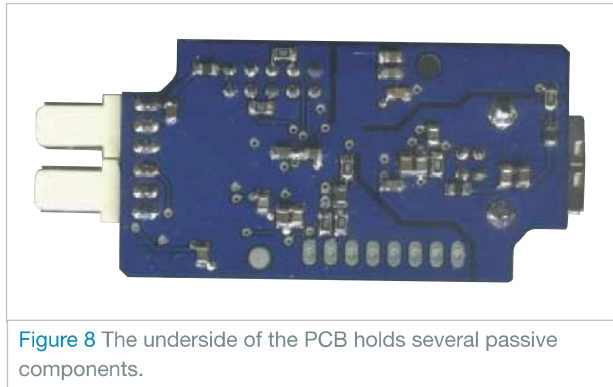

Figure 8 The underside of the PCB holds several passive components.

pickup (references 2 and 3). You might need to add external buffer amplifiers or a more precise voltage reference. The availability of a reference voltage and 3.3V power on the analog ports makes this setup possible. You can also use the DAC outputs in connector J₁ to trim a value or to provide an arbitrary voltage to the sensors. Note that J₁ also has five digital-I/O pins (Figure 1).

The design fits into a 2.36x1.38-in. enclosure (Figure 7). The underside of the PCB holds several passive components (Figure 8). Reference 4 provides details and enables you to download the entire design, as well as CAD/CAM files, bills of materials, and software. **EDN**

REFERENCES

- 1 Kopasz, Katalin; Peter Makra; and Zoltan Gingl, "Edaq530: a transparent, open-end and open-source measurement solution in natural science education," *European Journal of Physics*, Volume 32, February 2011, pg 491, <http://bit.ly/nGXz0o>.
- 2 C8051F35x Delta-Sigma ADC User's Guide, Silicon Laboratories, 2005, <http://bit.ly/qg4jgl>.
- 3 Kester, Walt; James Bryant; and Joe Buxton, "High resolution signal conditioning ADCs," Analog Devices, <http://bit.ly/ncGvNb>.
- 4 Gingl, Zoltan, "EDAQ24 24-bit microcontroller sensor-to-USB interface and data logger," 2011, <http://bit.ly/pHck47>.