

10/05/2002

AD7723

Z.Gingl

1

4

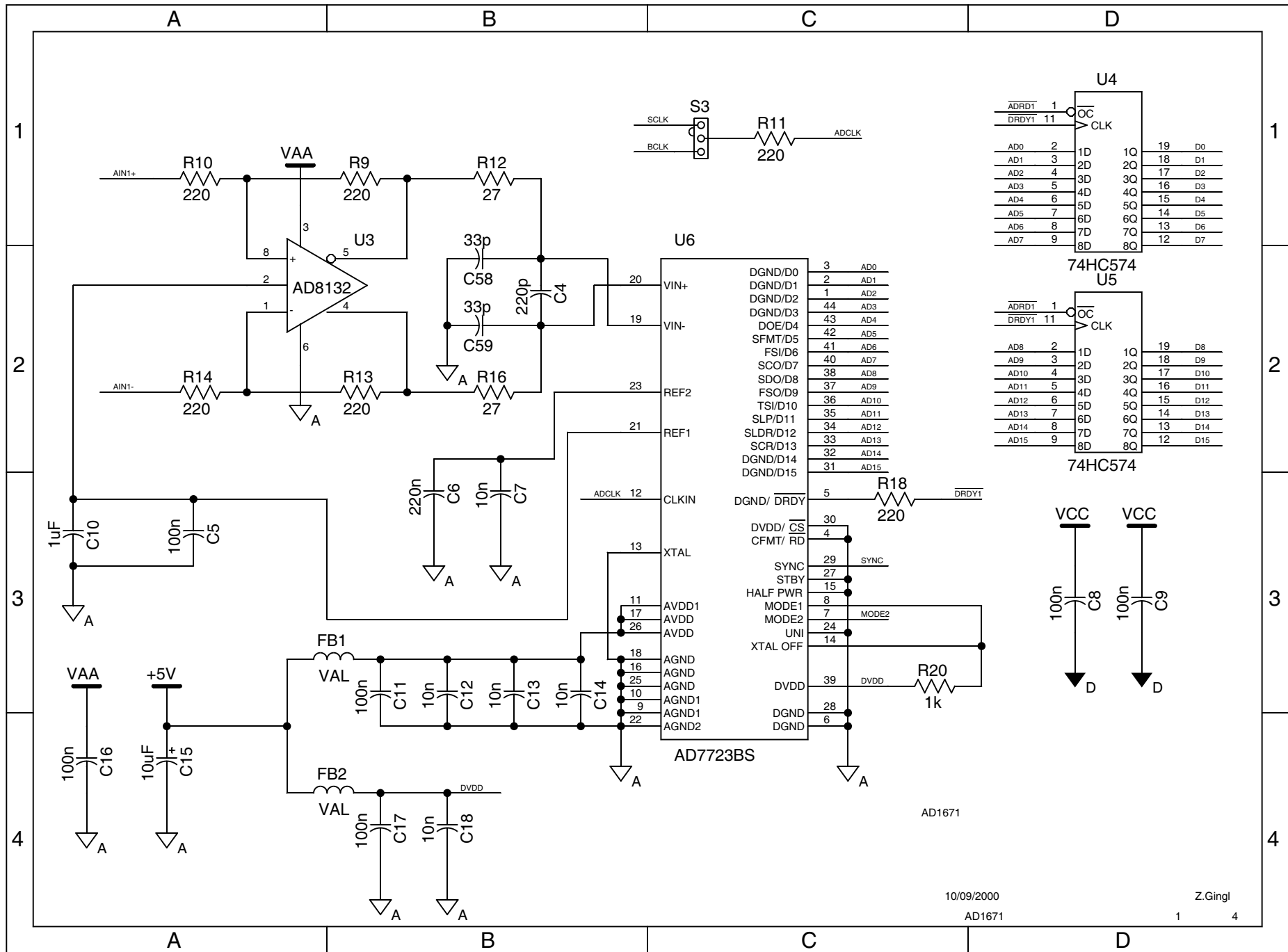

10/09/2000

Z.Gingl

AD1671

1 4

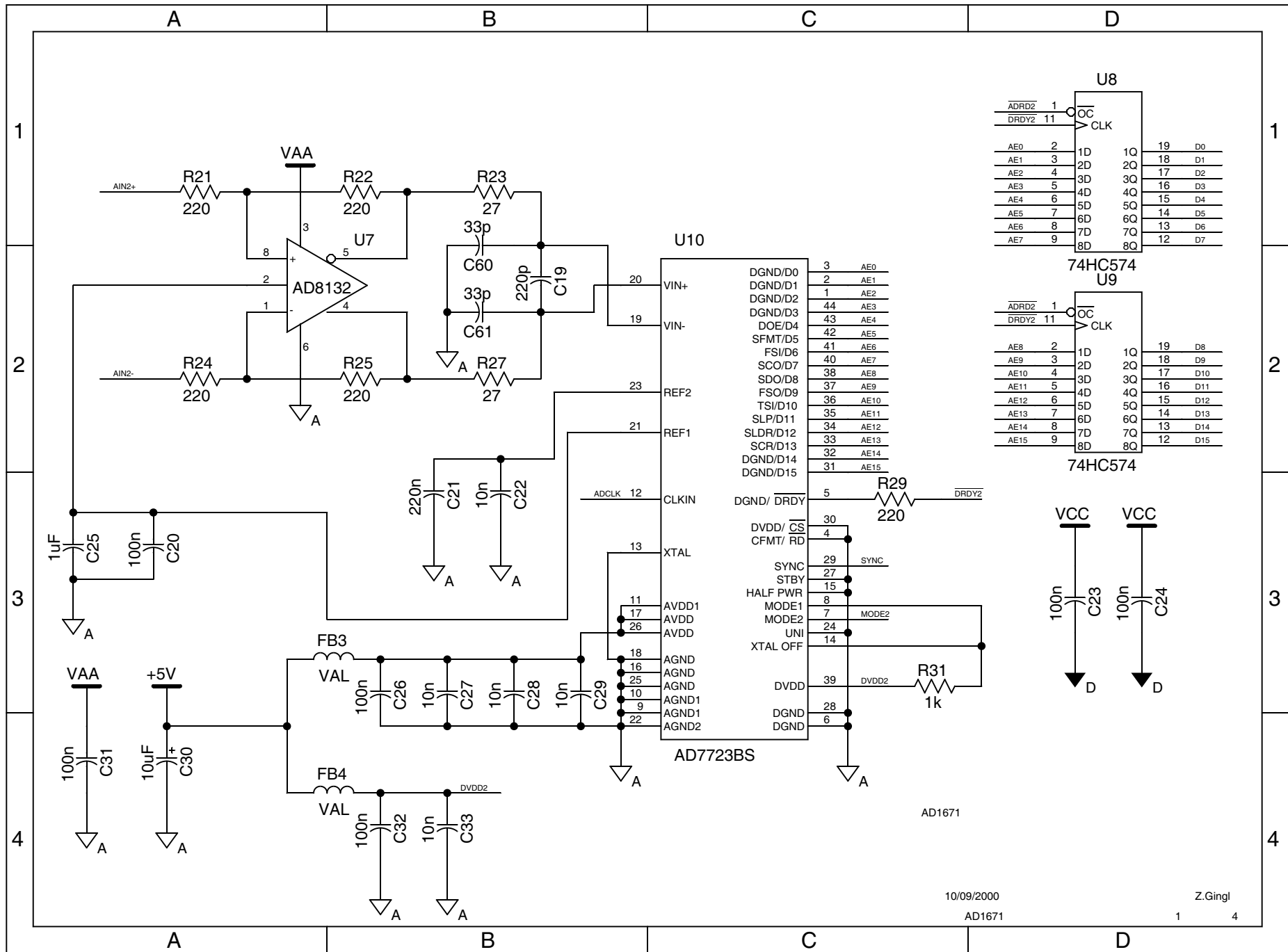

Pinout for U10 (AD7723BS):

3	AE0
2	AE1
1	AE2
44	AE3
43	AE4
42	AE5
41	AE6
40	AE7
38	AE8
37	AE9
36	AE10
35	AE11
34	AE12
33	AE13
32	AE14
31	AE15

Pinout for U8 (74HC574):

1	OC		
11	CLK		
2	1D	19	D0
3	2D	18	D1
4	3D	17	D2
5	4D	16	D3
6	5D	15	D4
7	6D	14	D5
8	7D	13	D6
9	8D	12	D7

Pinout for U9 (74HC574):

1	OC		
11	CLK		
2	1D	19	D8
3	2D	18	D9
4	3D	17	D10
5	4D	16	D11
6	5D	15	D12
7	6D	14	D13
8	7D	13	D14
9	8D	12	D15

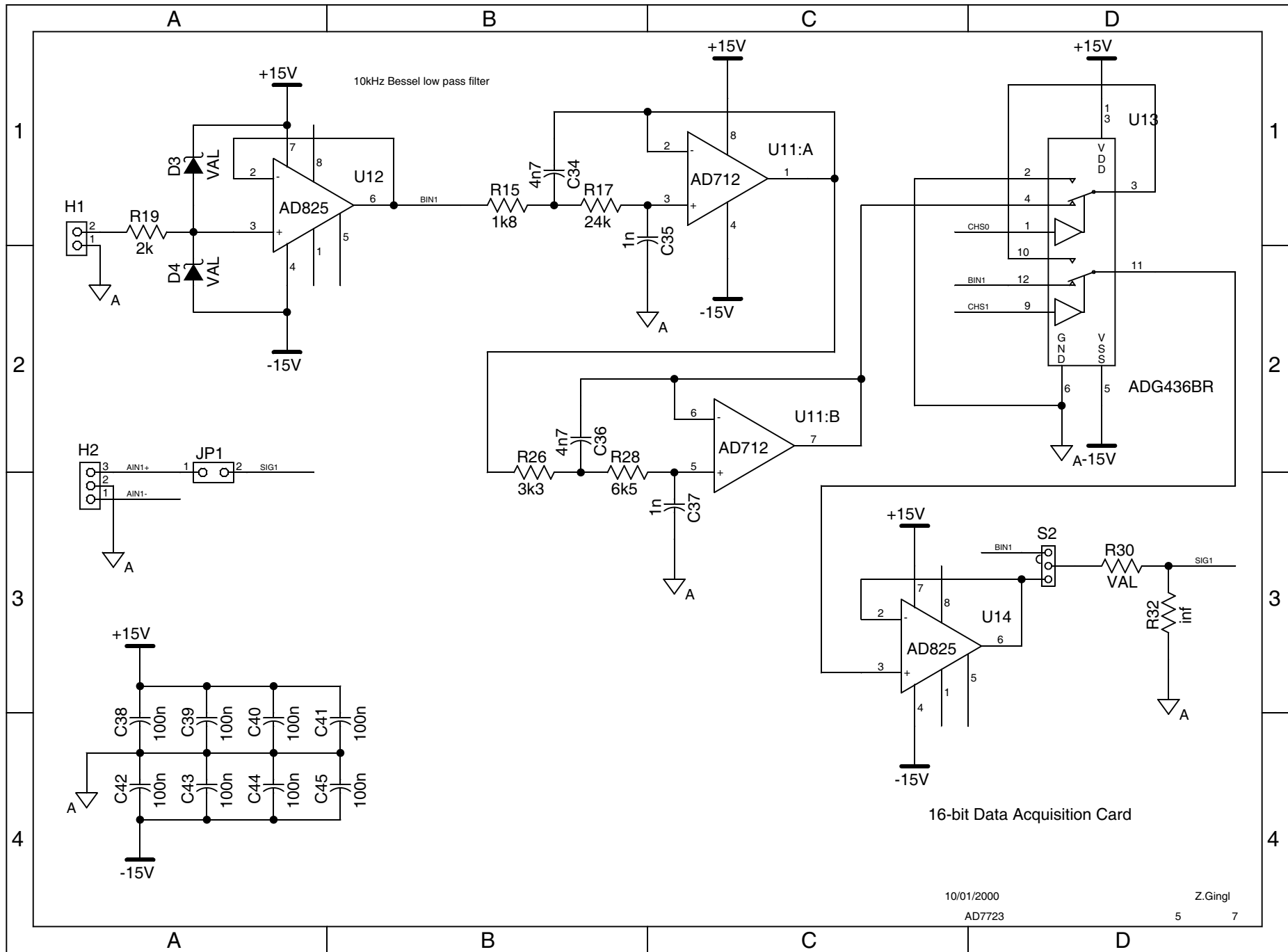

10/01/2000

Z.Gingl

AD7723

5 7

