

PCHI012

Hole Inspection lens for 1/2" detector



part number		PCHI012
Detector Size		1/2"
min. FOV (diam x height)	(mm x mm)	10 x 10
max. FOV (diam x height)	(mm x mm)	120 x 190
Wavelength range	(nm)	450 .. 650
Working distance	(mm)	5 .. 35
CTF @ 50 lp/mm	(%)	> 40
F-number		4,7
Diameter	(mm)	28,0
Length	(mm)	104,0
Weight	(g)	250
Mount		C

Rev No.	Description	Date	Name
D	PCHI012 layout	13/07/09	

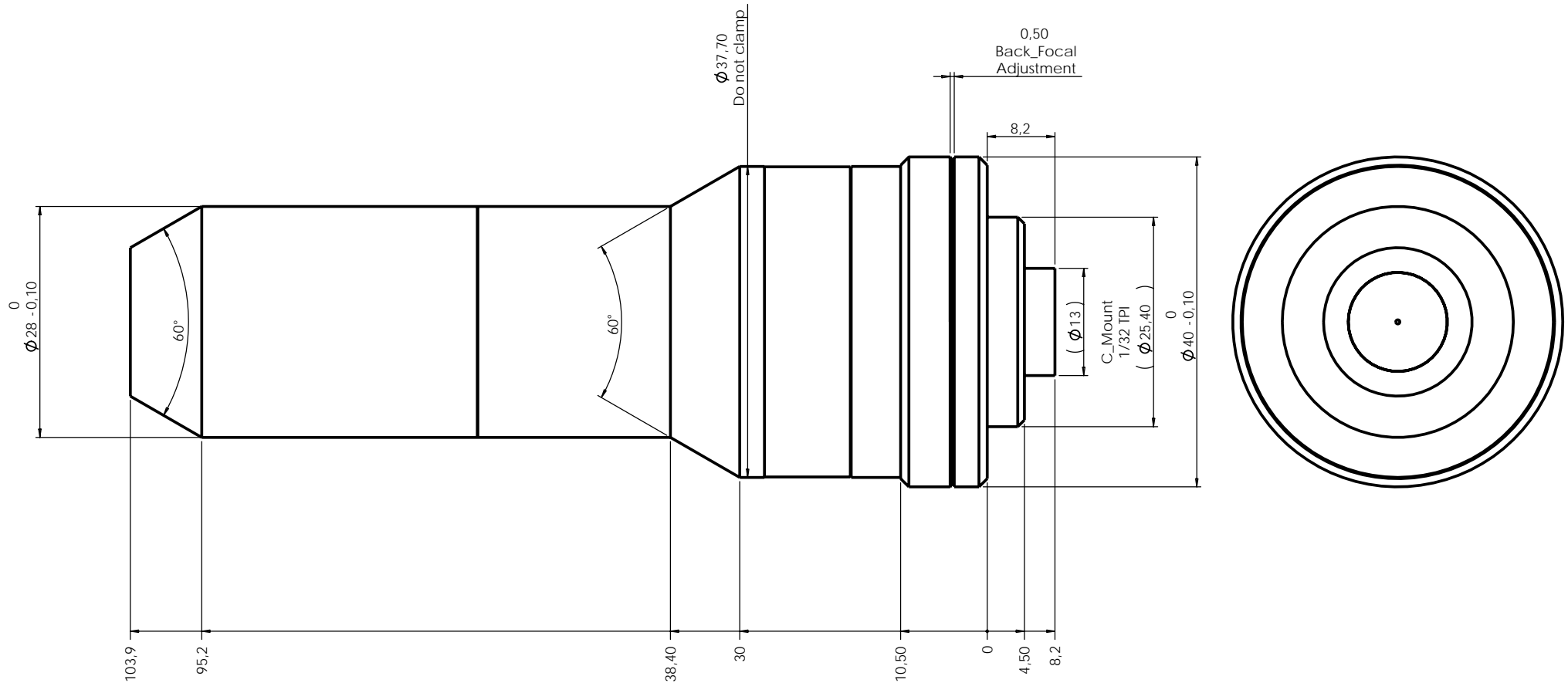

Material		N.A.				Mass	250 gr.	Scale	2:1
Surface treatment		N.A.				Project-Prod Item/Instrument PCHI012			
Geometrical tolerance (ISO 2768-2)						Class		K	
Linear tolerance (ISO 2768-2)						Class		m	
0.5	>3-	>6-	>30-	>120	>400-	>1000	>2000	Undimensioned bevels	
±3	6	30	120	±400	±1000	±2000	±4000	Undimensioned radii	
±0.1	±0.1	±0.2	±0.3	±0.5	±0.8	±1.2	±2	R 0.5	
Date						Name		Description	
Designed						13/07/09		PCHI012 layout	
Draw						13/07/09		Drawing No.	
Checked						X		18351-0-D	
						Date		Sheet	
www.opto-engineering.com								1/1	
OPTO ENGINEERING S.r.l. - 46100 Mantova Italy - Via Cremona, 29/2 - Tel. +39 0376 263565 - e-mai: info@opto-engineering.com - http://www.opto-engineering.com						Reproduction forbidden without specific authorization			